

Remote control (RD-21)

SPECIFICATIONS

Applicable disc	2-channel SACD, CD
Supported sampling frequencies	USB input (PCM) : 32k, 44.1k, 48k, 88.2k, 96k, 176.4k, 192k 352.8k, 384kHz (16, 24, 32bits) USB input (DSD) : 2.82M, 5.64MHz (1bit) COAX/OPT input : 32k, 44.1k, 48k, 88.2k, 96k, 176.4k, 192kHz (16, 20, 24bits)
Analog output voltage / impedance	2.5V/300Ω (unbalanced), 600Ω (balanced)
Frequency response	CD 5Hz to 20kHz (+0, -0.5dB) SACD 5Hz to 50kHz (+0, -3.0dB) USB 5Hz to 50kHz (+0, -3.0dB)
Total harmonic distortion	CD 0.0015%, SACD 0.0011%, USB 0.0009%
S/N ratio (IHF-A)	CD 122dB, SACD 104dB, USB 123dB
Disc drive mechanism	LxDTM
D/A converter	Burr-Brown-made PCM1792A (monaural mode) x 2
Output amplifier circuit	Fully balanced/high sound quality IC buffer
Power consumption	29W 1W (at standby)
Dimensions	440(W) x 133(H) x 410(D) mm front side knob of 2mm and rear side terminal of 8mm included in depth
Net weight	15.7kg
Accessories	Remote control (RD-21) Power cable Install software CD

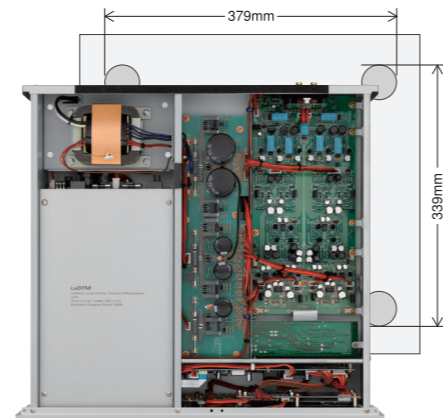

Internal configuration

Advanced 384 kHz/32-bit PCM and 5.64 MHz DSD\* supported

Currently, the PCM method that has been widely used including CD is a mainstream for high-resolution music distribution. The DSD method that is known for being used in SACD is alternatively becoming popular. The USB input of D-06u fully supports the noteworthy DSD method as well as the PCM method. This unit strongly exploits the nuance of the DSD method different from the PCM method's, and make the most of what the DSD method offers. The supported specification is, at the USB input in operation, up to 5.64MHz with the DSD method and up to 384 kHz/32 bits (up to 192 kHz/24 bits at the S/PDIF input in operation) with the PCM method. Today, sound sources are provided mainly at up to 192 kHz/24 bits with the PCM method and 2.82 MHz with the DSD method by music distribution services. However, D-06u secures playback specifications exceeding those values. D-06u offers the leading-edge environment, for-seeing the progress of sound sources.

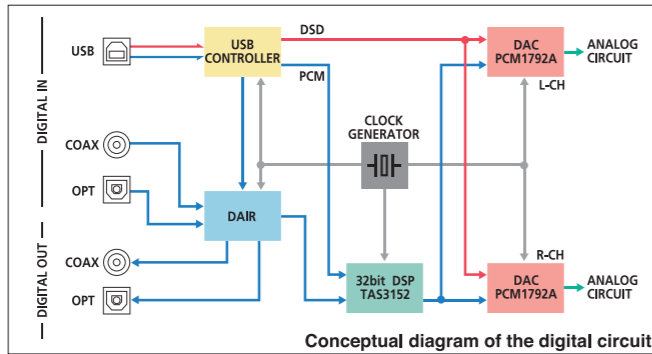

\* DSD is an abbreviation for "Direct Stream Digital" that is a digital method in which a sound compression wave travelling in the air is utilized in data structure.

Luxman's original audio playback software for high sound quality

Playback software needs to be installed to play back a general lossless compressed FLAC file acquired through music distribution or a DSD file that is about to spread with use of a PC or a Mac. Luxman's dedicated playback software, "LUXMAN Audio Player", is available. What you need is only to install the software from the attached CD to start enjoying the music. The following file formats, FLAC, ALAC, WAV, AIFF, MP3, DSF, and DSDIFF, are supported, covering formats used by major music distribution sites. The software is compatible with both Windows and Mac. Comfortable operability using a simple interface is also what LUXMAN thinks an important factor.



LUXMAN Audio Player

\* Windows is a registered trademark or a trademark of Microsoft Corporation in the United States and/or other countries.  
\* Mac is a registered trademark or a trademark of Apple Inc. in the U.S. and other countries. \* DSD is a registered trademark.



IAG House, 13/14 Glebe Road, Huntingdon, Cambridgeshire, PE29 7DL, UK  
Tel: +44 (0) 1480 452561 Fax: +44 (0) 1480 413103 http://www.luxman.com  
LUXMAN CORPORATION, 1-3-1 Shinyokohama, Kouhoku-ku, Yokohama-shi, Kanagawa 222-0033, Japan  
Tel: +81-45-470-6980 Fax: +81-45-470-6997 http://www.luxman.com  
IAG reserves the right to alter the design and specifications without notice. All rights reserved IAG Group Ltd.  
Luxman is a member of the International Audio Group. Code:LN14-LL0006

**Safety Cautions**

To ensure correct use of this product, read the "Owner's Manual" prior to use. Failure to follow all safeguards can result in fire, electric shock, or other accidents.

\*Design and specifications are subject to change without notice.





# Genealogy of the flagship, concentrating digital playback charms



D-06u succeeding the magnificent configuration of our flagship model, D-08u, is a CD/SACD player that plays back file sound sources by connecting to a Windows or Mac PC via USB.

LxDTM\*, Luxman's original disc drive mechanism with overwhelming rigidity and high reading accuracy is provided to stabilize the rotation system at disc media playback, and the latest high sound quality configuration including 32-bit digital signal processor is provided in the digital circuit.

The leading-edge USB D/A converter is provided to support 384 kHz/32-bit PCM and 5.64 MHz DSD, for-seeing the further progress of file sound sources. With the enhanced charm as "Digital Media Player", D-06u proposes a new style to play back the music.



## Advanced digital circuit

D-06u is equipped with dual-configured (monaural mode) PCM1792A D/A converter that has achieved ultra-high S/N ratio and dynamic range (theoretical value: 132 dB) manufactured by Texas Instruments Incorporated to support playback of not only CDs and SACDs but also file sound sources of up to 384 kHz/32-bit PCM data and DSD data (2.82 M, 5.64 MHz) by connecting a Windows or Mac PC via USB. TAS3152, the latest 32-bit digital signal processor manufactured by Texas Instruments Incorporated, upsamples PCM signals to up to 384 kHz to polish the sound quality. Thanks to the function of the chip mentioned above, a digital filter is selectable from 3 types for PCM signals, and a tone is selectable from 2 types made by the DAC chip-embedded analog FIR filter for DSD signals. As counter-measures against jitter, the jitter of USB signals is reduced by the dedicated DSP via asynchronous communication, the jitter of CD or S/PDIF signals is reduced by the embedded DAIR high-precision clock, and the jitter of SACD signals is reduced by the dedicated jitter reduction chip. In addition, the low phase noise clock module improves the accuracy of the entire signal transmission.

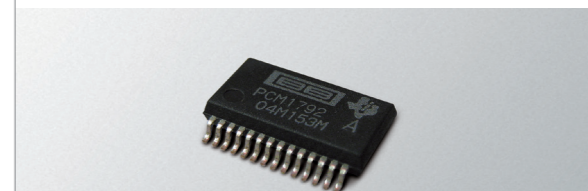

D/A converter PCM1792A



Digital signal processor TAS3152

## Balanced amplifier circuit

A high-grade analog amplification circuit is necessary to convert playback signals that have been precisely read by the drive mechanism and sophisticatedly digitized into analog signals through the highly precise D/A converter and produce high-quality audio signals finally by the player. D-06u makes the differential output of the D/A converter, operating at the monaural mode reduce the impedance by the high sound quality buffer circuit with thoroughly balanced configuration (identically configured amplifier x 4 units). This unit powerfully drives the next stage components such as a pre-main amplifier and a control amplifier. The high-inertia power supply system through the regulators and block capacitor with large capacity allocated for each circuit powerfully supports stable operation with sufficient power from Luxman's traditional audio-specific power transformer.

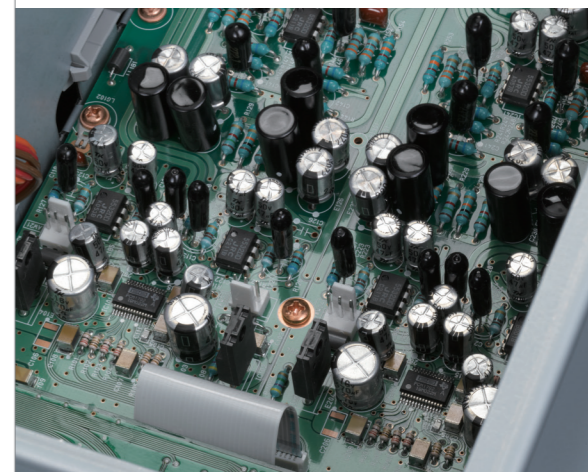

Solid state amplifier circuit

## Wide variety of digital input terminals

PCM digital input terminals consisting of 1 channel of coaxial line capable of up to 192 kHz/24 bits and 1 channel of optical line as well as USB port ready for DSD/PCM signals on the rear panel. This unit, therefore, can be a digital center connecting to various digital sources.



Digital input/output terminals

## Gradation cast-iron leg

Gradation cast-iron legs are used to prevent resonance thanks to its characteristics that the metallic structure becomes smaller from the center to the periphery of the leg to suppress external vibration transmitted from the contact area and unnecessary vibration generated in the cabinet itself.



Gradation cast-iron insulator leg

## Zoom display mode

The highly-visible dimmer function-equipped FL display that stands out against gorgeous-looking blasted white sophisticated finishing is equipped with the zoom mode that is useful for operating with a remote control.



Zoom mode-equipped FL display

## Comfortable remote control operation

The aluminum-made dedicated remote control is supplied for comfortable operation while you are in an ideal listening position. This remote control is a slim type comfortably fit in your hand, yet, has ten keys, and is excellent in operability.



Dedicated remote control (RD-21)

## Original mechanism LxDTM

D-06u is equipped with LxDTM, LUXMAN original high-rigidity disc drive mechanism. The box chassis structure that covers the entire base section storing the traverse allows external vibrations to be rigidly blocked out and enables reading digital signals with sufficient accuracy. This mechanism has adopted an asymmetrical left-sided mechanism layout after careful consideration of sufficient space for voluminous analog circuit, ideal flow for all kinds of signals, oscillatory path, and weight balance without the use of general type centered mechanism structure. Thick die-cast aluminum is used for the loader on which a disc is put. Use of this loader can fundamentally eliminates unnecessary resonance and vibration that are applied to the loader and provide quiet and smooth operation.

\* LxDTM is an abbreviation for Luxman original Disc Transport Mechanism.